

NOVA



INSTALLATION GUIDELINE

V 1.0



Ground Mounting System

NOVA DOUBLE POST



25 YEAR WARRANTY



UP-TO 30% FASTER INSTALLATION



PORTRAIT



TILT ANGLE From 5°-60°

WWW.NOVAMOUNTING.COM

CONTENT

1. INTRODUCTION	1
2. GENERAL.....	1
LIABILITY.....	1
INSTALLATION GUIDELINES	1
TESTING & CERTIFICATION	1
MAINTENANCE.....	1
DISASSEMBLY & DISPOSAL	1
WARRANTY	1
3. SAFETY GUIDELINE.....	2
PERSONNEL & SUPERVISION	2
WORKSITE SAFETY.....	2
MANDATORY SAFETY CHECKS.....	2
GENERAL RESPONSIBILITY & SAFETY GUIDELINE	2
4. SYSTEM OVERVIEW	3
PARTS LIST	4
5. INSTALLATION PREPARATION	6
TOOL LIST	6
MEASURE THE SOLAR MODULES.....	6
GROUND SCREW SET UP	7
CONCRETE SET UP	7
PILE DRIVEN SET UP.....	7
6. INSTALLATION GUIDELINE	8
SPACING LAYOUT	8
INSTALLING THE UPRIGHT COLUMNS TO THE BASE PLATES	9
INSTALLING THE SUPPORTING FRAME.....	10
INSTALLING THE SUPPORTING FRAME.....	11
INSTALLING THE SUPPORTING FRAME.....	12
JOINING RAILS.....	13
CORRECT RAIL JOINER LOCATION	14
INSTALLING RAIL ONTO THE SUPPORT FRAME	15
RAIL INSTALLATION COMPLETED.....	16
INSTALLING THE REAR SUPPORT BRACE (OPTIONAL)	17
NOVA MODULE CLAMPS	18
CORRECT POSITIONING OF NOVA MODULE CLAMPS.....	19
INSTALLING THE FIRST SOLAR MODULE.....	20
INSTALLING THE SUBSEQUENT SOLAR MODULES.....	21
INSTALLING THE LAST SOLAR MODULE OF THE ROW	23
SOLAR MODULE INSTALLATION COMPLETED	24
7. NOTE	25

1. INTRODUCTION

Welcome to the NOVA Solar Mounting Solution Installation Guideline. This guide is your comprehensive resource for installing NOVA's solar mounting systems. Designed with precision and engineered for durability, our systems ensure a seamless and efficient installation experience.

Whether you're working with penetrative tin roofs, tile roofs, or other specialised surfaces, this guideline provides step-by-step instructions and all the necessary details to ensure a successful and long-lasting solar installation.

2. GENERAL

This installation guideline outlines the correct procedure for assembling the NOVA Ground Mounting System and must be followed precisely. Before beginning installation, please read this guideline carefully to ensure full understanding of the process and associated safety requirements. Compliance with all safety precautions, handling guidelines, and the procedures outlined in this guideline is essential for a safe and successful installation.

In addition to this guideline, refer to any project-specific layout drawings, engineering reports, or planning documents provided by NOVA Mounting. These documents contain important technical data and site-specific instructions that must be adhered to throughout the installation process.

Please note that the illustrations and diagrams within this guideline are provided for general guidance and may differ slightly from actual system configurations depending on roof type, region, or project requirements.

LIABILITY

All technical content and guidance contained in this guideline is developed using current standards, regulations, and NOVA Mounting's expertise in solar mounting systems. While every effort has been made to ensure accuracy, final responsibility lies with the installer to verify compliance with local codes, structural suitability, and safe work practices. Refer to our official warranty and liability conditions available at www.novamounting.com

INSTALLATION GUIDELINES

Ensure that the roof construction is suitable for the introduction of forces at the fixing points and their subsequent transmission. In order to compensate thermal expansion, include a break every 25 meters when planning the PV-system. For module positioning/fastening points please refer to manufacturers recommendations. Please follow your local timber construction standard. Please do not use installed roof connections as ladder. If installation is located within 10km from the coast, we advise not to use zinc coated material. For further information please contact your sales representative or the technical department at NOVA Mounting.

TESTING & CERTIFICATION

All components have been tested and developed to be compliant with relevant guides and regulations.

MAINTENANCE

To ensure the long-term safety, performance, and structural integrity of the NOVA Mounting System, periodic inspections and maintenance are required. All maintenance activities must be carried out by qualified personnel familiar with the system and local safety standards.

- Perform a general system inspection annually. Additional inspections should be conducted after severe weather events, such as storms with wind speeds exceeding 75 km/h or heavy hail.
- Inspect all screw connections and tighten any that are loose, following the specified torque values provided in the installation instructions
- Any damaged, corroded, or loose components must be repaired or replaced immediately.

DISASSEMBLY & DISPOSAL

Reused components are classified as wearing parts, and responsibility for assessing wear rests with the installer. NOVA disclaims any liability or warranty for reused components. Disassembled parts should be properly recycled, with metals and plastics sent for recycling, and other materials disposed of according to their composition.

WARRANTY

Warranty according to the terms and conditions found on the website www.novamounting.com

NOVA is not accountable for the roof's capability to maintain the introduced forces. Please check the roof's compatibility with a static engineer.

3. SAFETY GUIDELINE

Before commencing installation, ensure the mounting surface is structurally sound and suitable for the applied loads of the solar array. All installations must be performed in accordance with the system design, local building codes, and relevant Australian Standards. Carefully plan the panel layout to accommodate thermal expansion—introducing expansion joints every 25 metres is recommended. Always follow the solar panel manufacturer's guidelines regarding clamping zones and attachment points. Do not use mounting components as footholds or for temporary access. Ensure the roof surface is clean, dry, and free of debris before beginning work. If in doubt, consult a structural engineer or contact NOVA Mounting's technical support for project-specific guidance.

PERSONNEL & SUPERVISION

- Installation must be carried out by qualified and trained personnel, with a minimum of two professionals present at all times
- All installers must be familiar with this guideline and local safety standards before beginning work.

WORKSITE SAFETY

- Never install the mounting system in high winds, wet conditions, or on slippery or uneven roof surfaces.
- Keep the roof clean and dry. Remove any algae, debris, or obstacles before beginning installation.
- Do not walk on the mounting system or solar panels at any time.
- Never stand in gutters or areas not designed to support weight.
- If working on tiled roofs, slide tiles upward to create footholds—do not damage tiles or roof structure.

MANDATORY SAFETY CHECKS

- Do not alter or substitute system components.
- Ensure all fasteners are tightened to the recommended torque (12–14 N.m).
- Double-check all fixings before finalising installation.

GENERAL RESPONSIBILITY & SAFETY GUIDELINE

Ladders & Access Equipment: Place ladders on stable, solid surfaces. Maintain a ladder angle of approximately 75°, and ensure it extends at least 1 metre above the roof edge. Where possible, secure the ladder at the top using a rope or tension strap.

Handling and Modification: Do not throw or roughly handle any components. Avoid bringing the system into contact with sharp or heavy objects. Do not modify components in any way, including exchanging bolts, drilling holes, or bending parts. Any such modifications not described in the standard installation procedure will void the warranty.

Roof Inspection: Before installation, verify the roof's load-bearing capacity. Check that the roof is in good condition and can support the weight of the solar panels, including additional materials and loads.

Weather Conditions: Avoid installation in adverse weather conditions, such as strong winds or wet, slippery surfaces.

Safety Measures: Follow all fire regulations related to photovoltaic installations. Ensure the roof surface is clean, dry, and free of debris before beginning installation. Use safety nets and edge protection as necessary.

Earthing and Bonding: Perform equipotential bonding, grounding, and earthing according to country-specific standards and regulations. Galvanising of all earthing components if required.

Protective Gear: Wear appropriate protective equipment such as helmets, gloves, and non-slip safety boots.



4. SYSTEM OVERVIEW

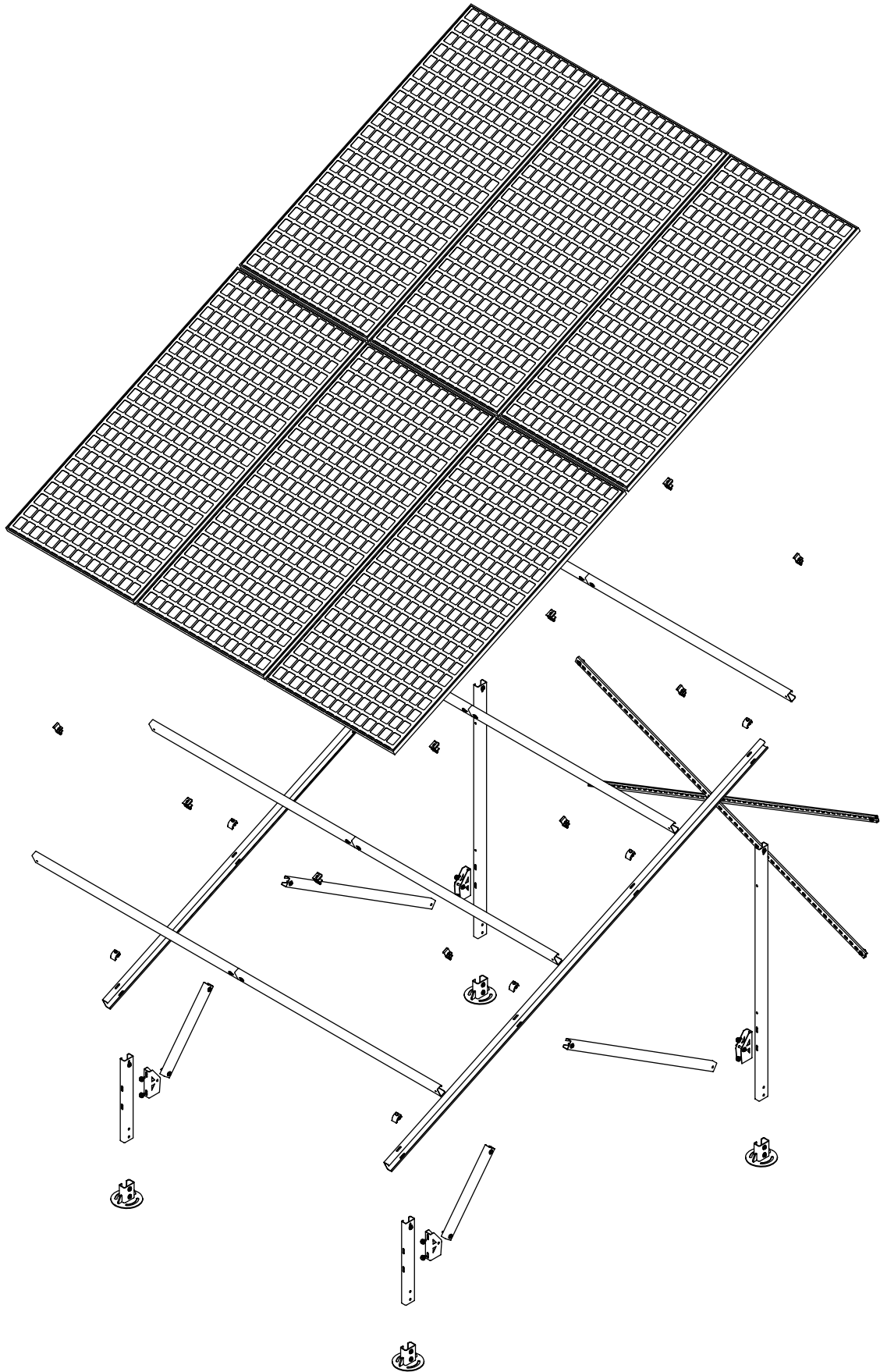

PARTS LIST

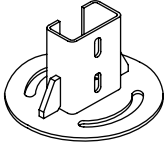

PART NAME:
BASE PLATE



PART NAME:
SUPPORT CONNECTOR



PART NAME:
REAR UPRIGHT COLUMN

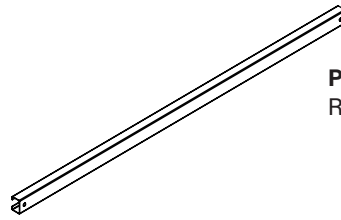

PART NAME:
REAR COLUMN SUPPORT BRACE



PART NAME:
FRONT UPRIGHT COLUMN

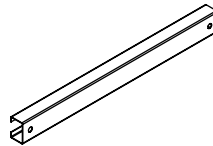

PART NAME:
FRONT COLUMN SUPPORT BRACE



PART NAME:
REAR SUPPORT BRACE

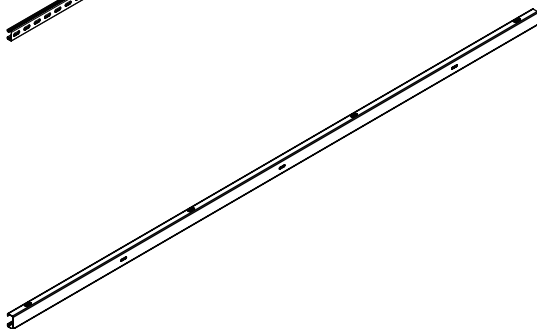

PART NAME:
SUPPORT BEAM

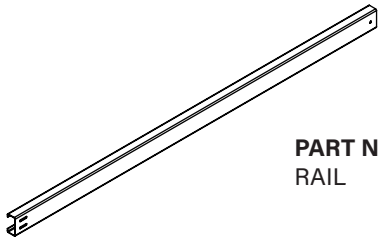

PART NAME:
RAIL

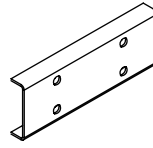

PART NAME:
RAIL JOINER

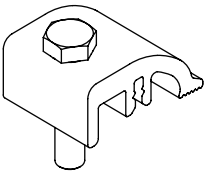

PART NAME:
RAIL CLAMP

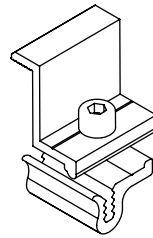

PART NAME:
END MODULE CLAMP

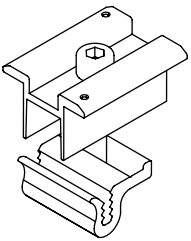

PART NAME:
INNER MODULE CLAMP

5. INSTALLATION PREPARATION

TOOL LIST



**MARKER
CHALK**



**TAPE
MEASURE**



**PLIERS
TIN SNIPS**



**PROTECTIVE
EQUIPMENT**



**STRING
LINE**



**CIRCULAR
SAW**



**IMPACT
DRIVER**



**NUT
SETTER**

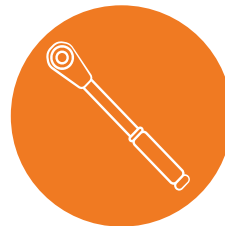

**TORQUE
WRENCH**



**SPIRIT LEVEL
SET SQUARE**

MEASURE THE SOLAR MODULES

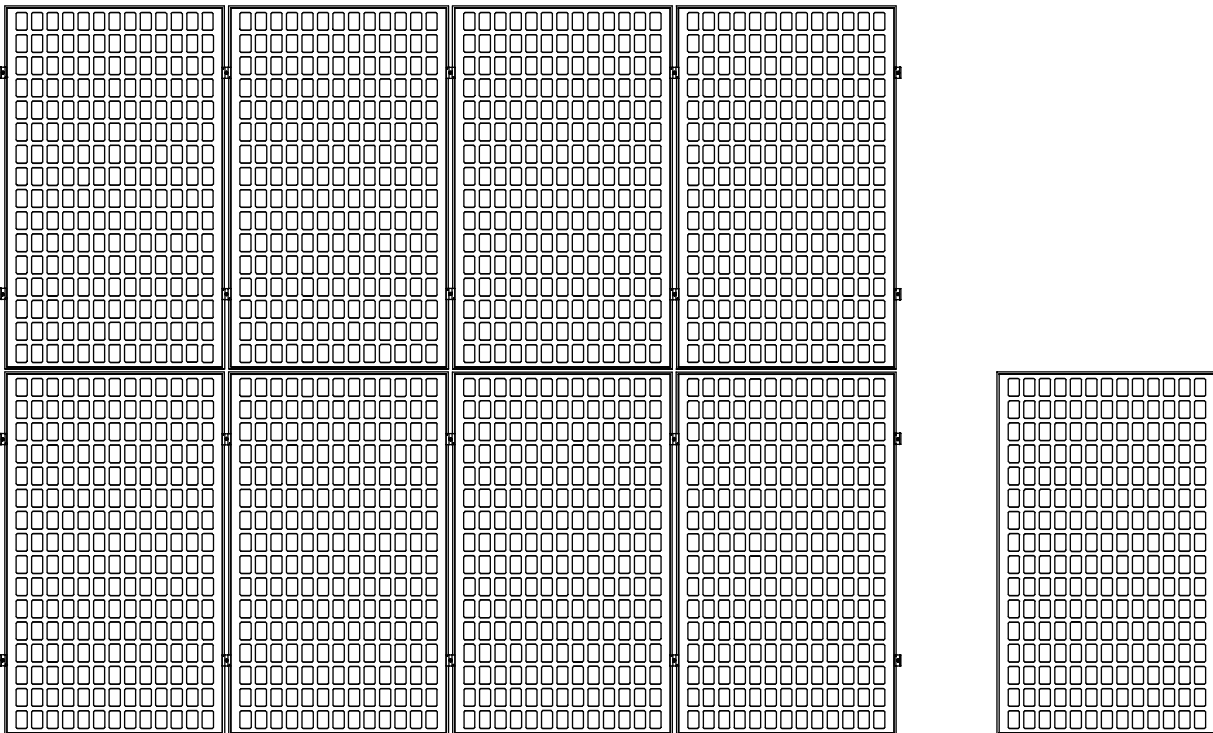

- Take the dimensions of the array field from the planning documents.
- Determine module size.
- Determine and mark positions of ground mounts.

GROUND SCREW SET UP

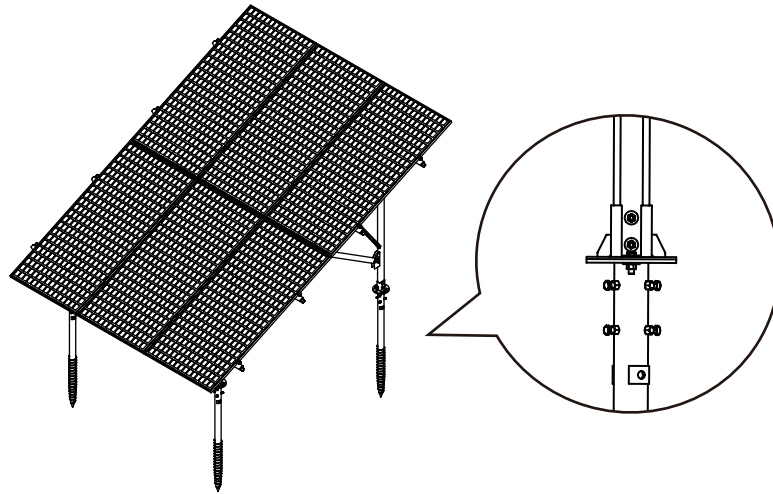

- Take the dimensions of the array field from the planning documents.
- Determine module size.
- Determine and mark positions of foundation.

CONCRETE SET UP

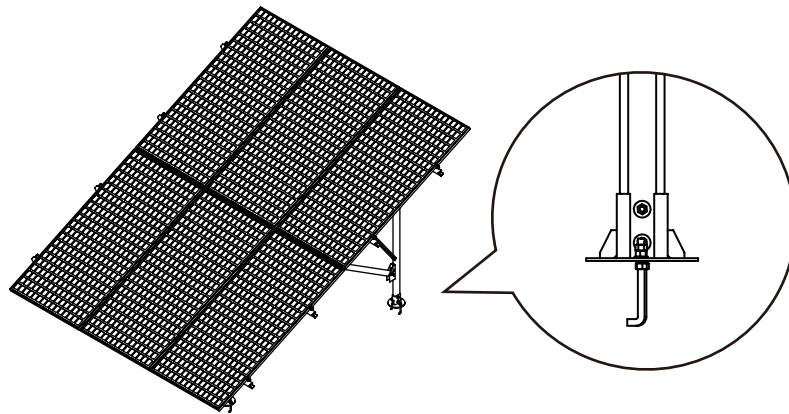

- Take the dimensions of the array field from the planning documents.
- Determine module size.
- Determine and mark positions of foundation.

PILE DRIVEN SET UP

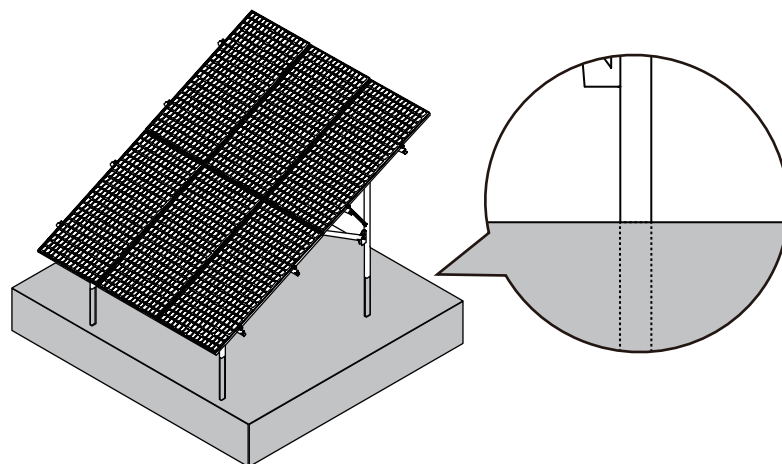

- Take the dimensions of the array field from the planning documents.
- Determine module size.
- Determine and mark positions of foundation.



Refer to the engineering documentation to determine the required spacing.

6. INSTALLATION GUIDELINE

SPACING LAYOUT

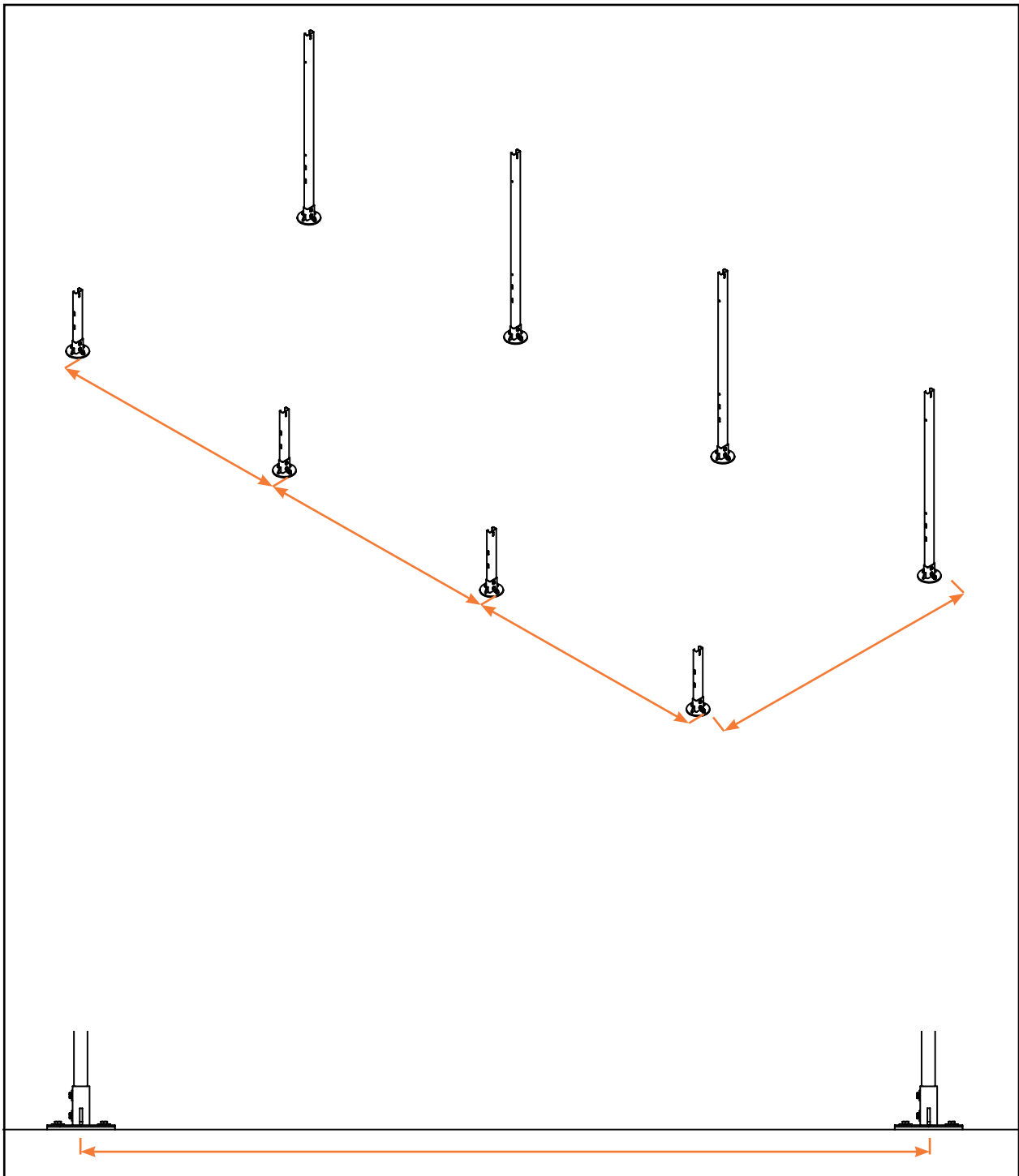

Ensure the spacing is correct as specified in the engineering documentation.

INSTALLING THE UPRIGHT COLUMNS TO THE BASE PLATES

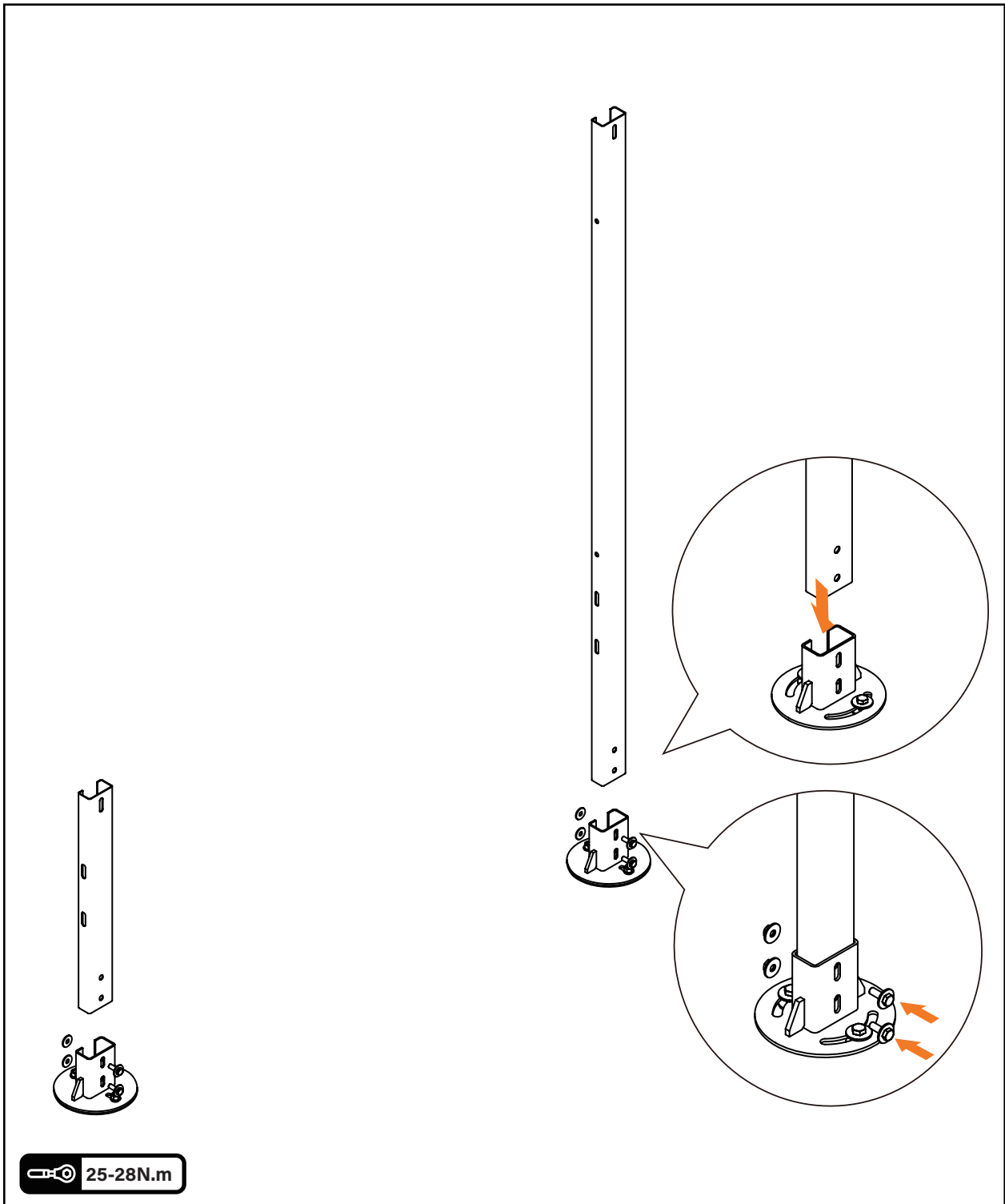

Insert the upright columns into the base plate. Insert the bolt and nut, then tighten them securely. Tighten the M10 bolt to the specified torque: 25–28N.m.

INSTALLING THE SUPPORTING FRAME

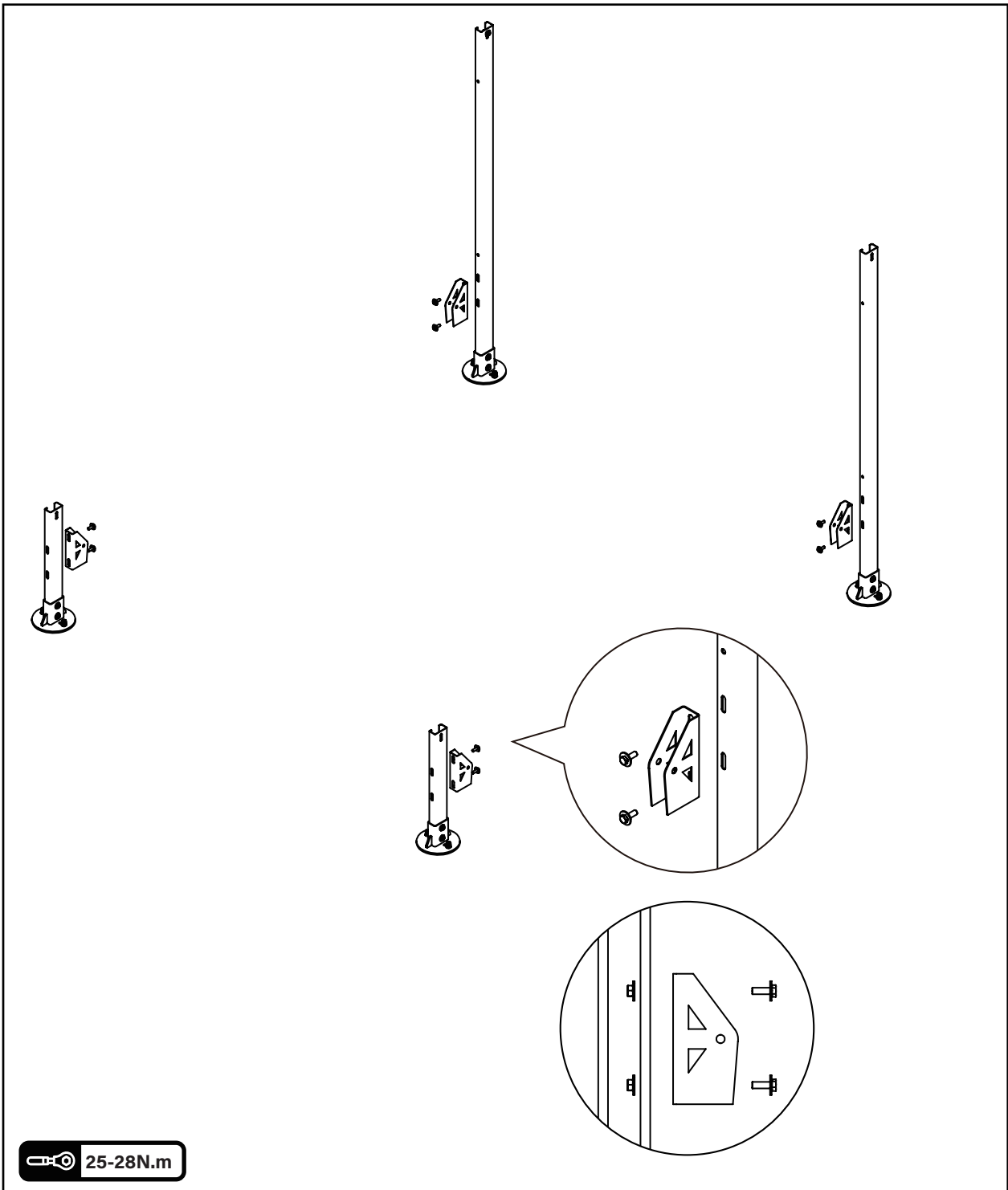

Install the support connectors onto the front and rear upright columns.
Tighten M10 bolts to the specified torque: 25-28N.m.



Ensure the support connector is installed in the correct orientation before securing.

INSTALLING THE SUPPORTING FRAME

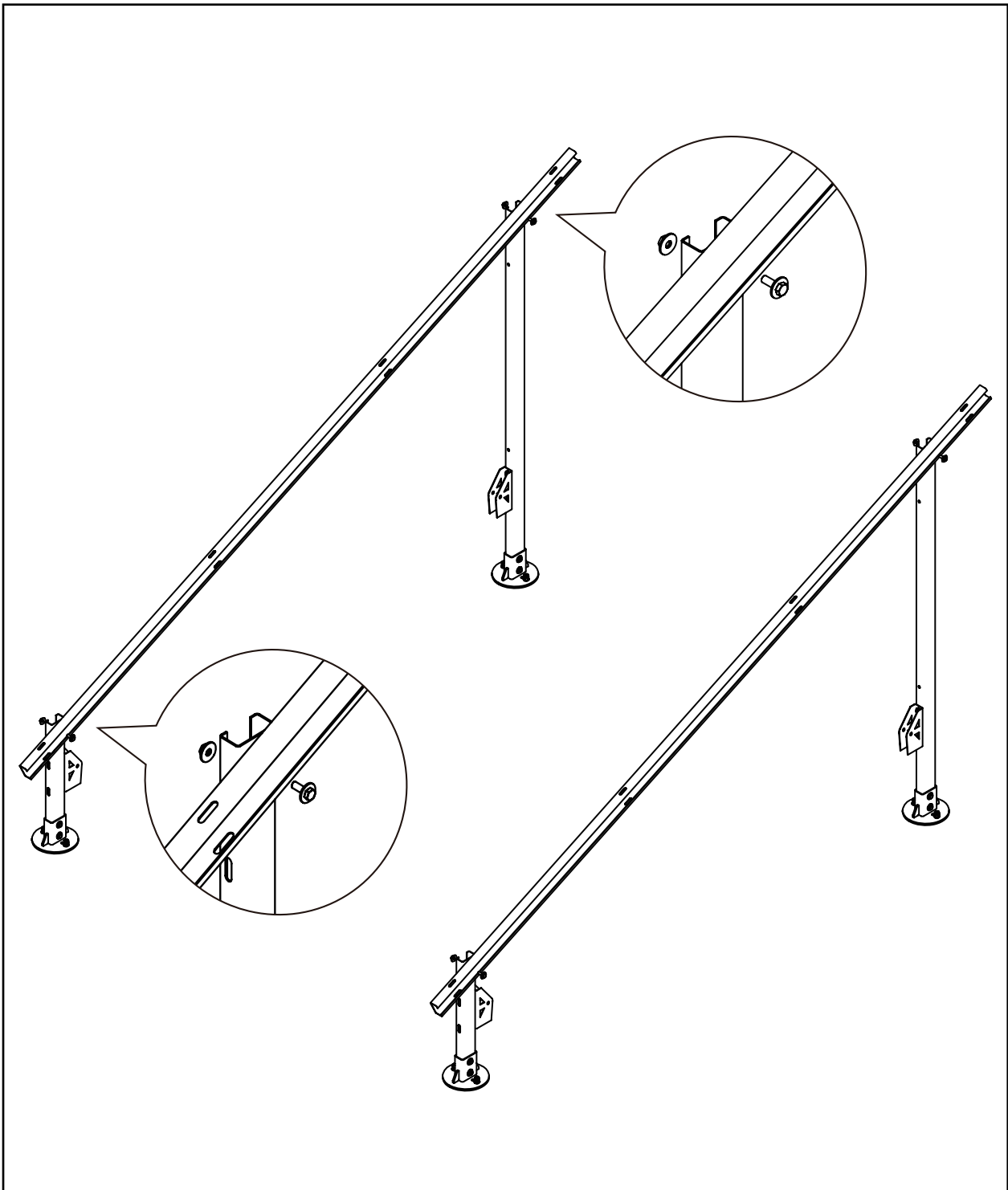

Loosely attach the support beam to the top of the front and rear columns.

INSTALLING THE SUPPORTING FRAME

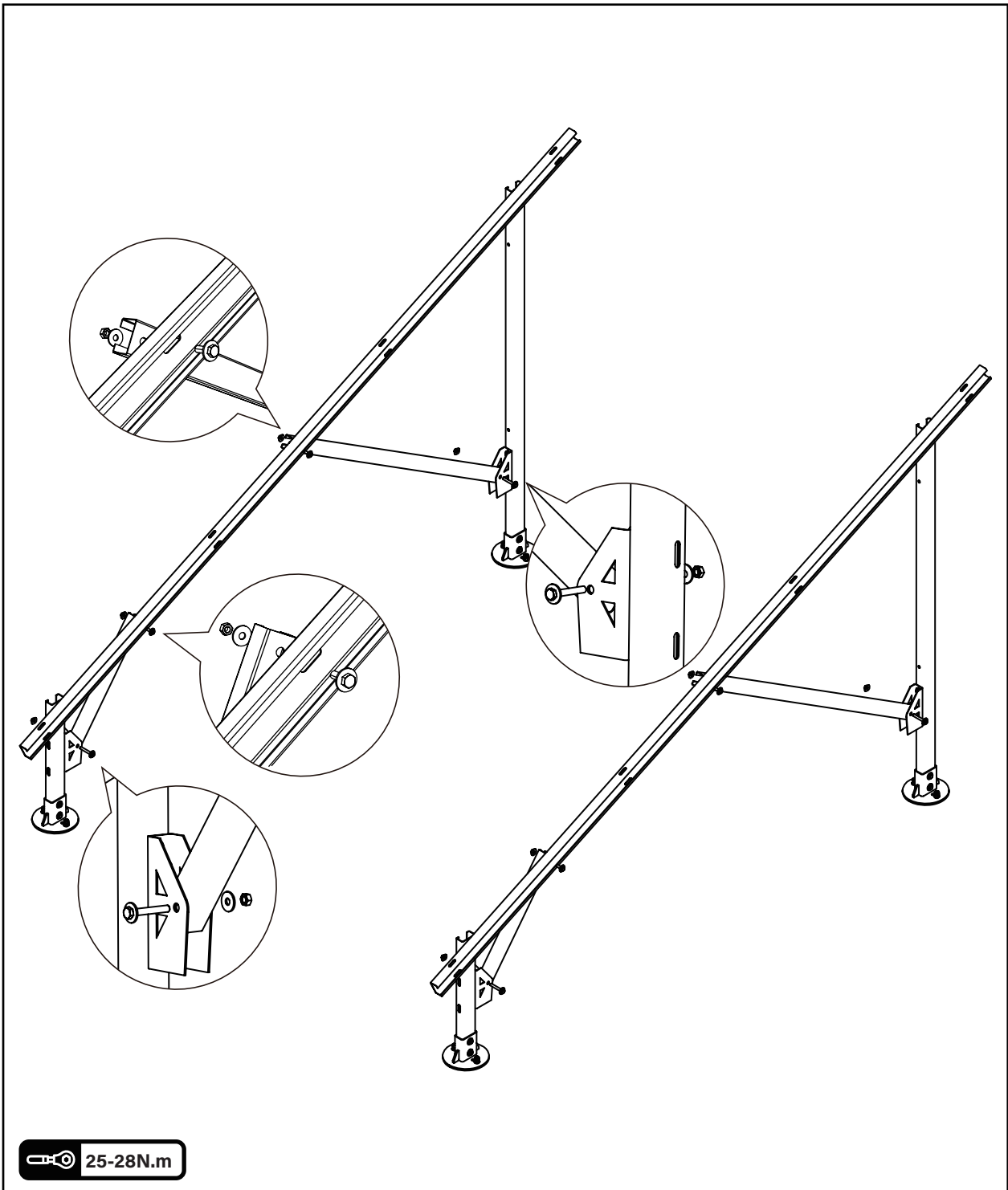

Install the front and rear support beam braces.
Once alignment is complete, tighten M10 bolts to the specified torque: 25–28N.m.

- i Repeat the steps above until all subsequent supporting frames in the same row are assembled, ensuring the row of frames are level and properly squared.

JOINING RAILS

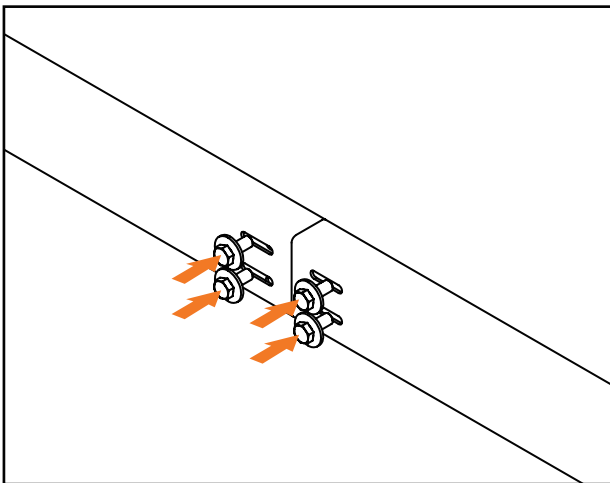
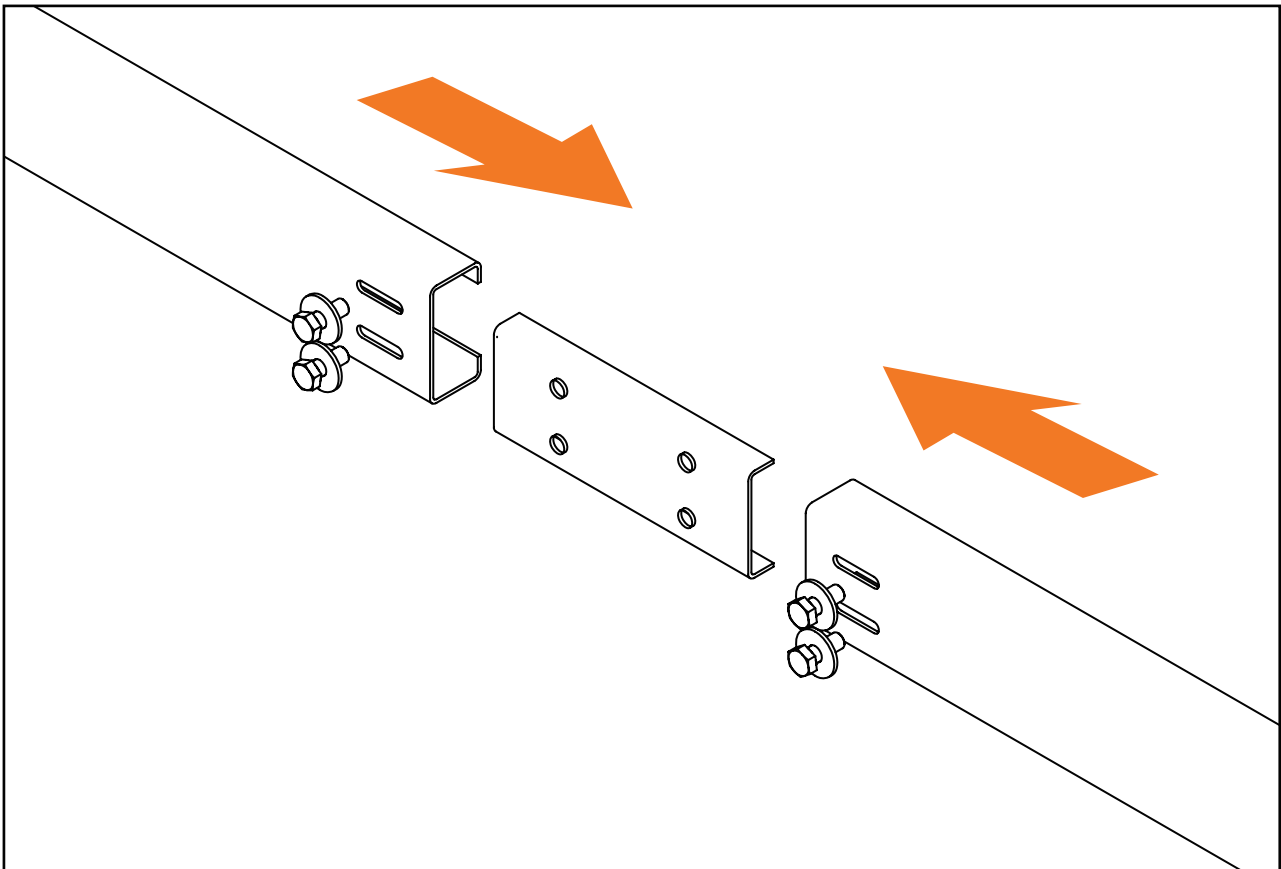
**STEP 1**

Align the internal joiner with the rail, ensuring it is centered between the two joining rails.

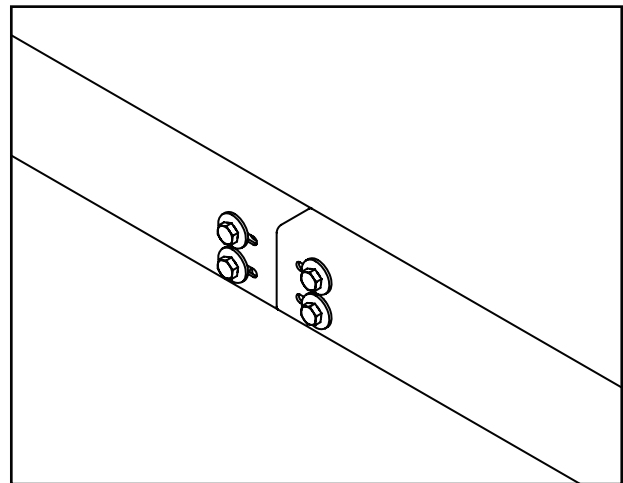
**STEP 2**

Tighten M10 bolts to the specified torque: 25-28 N.m.

CORRECT RAIL JOINER LOCATION

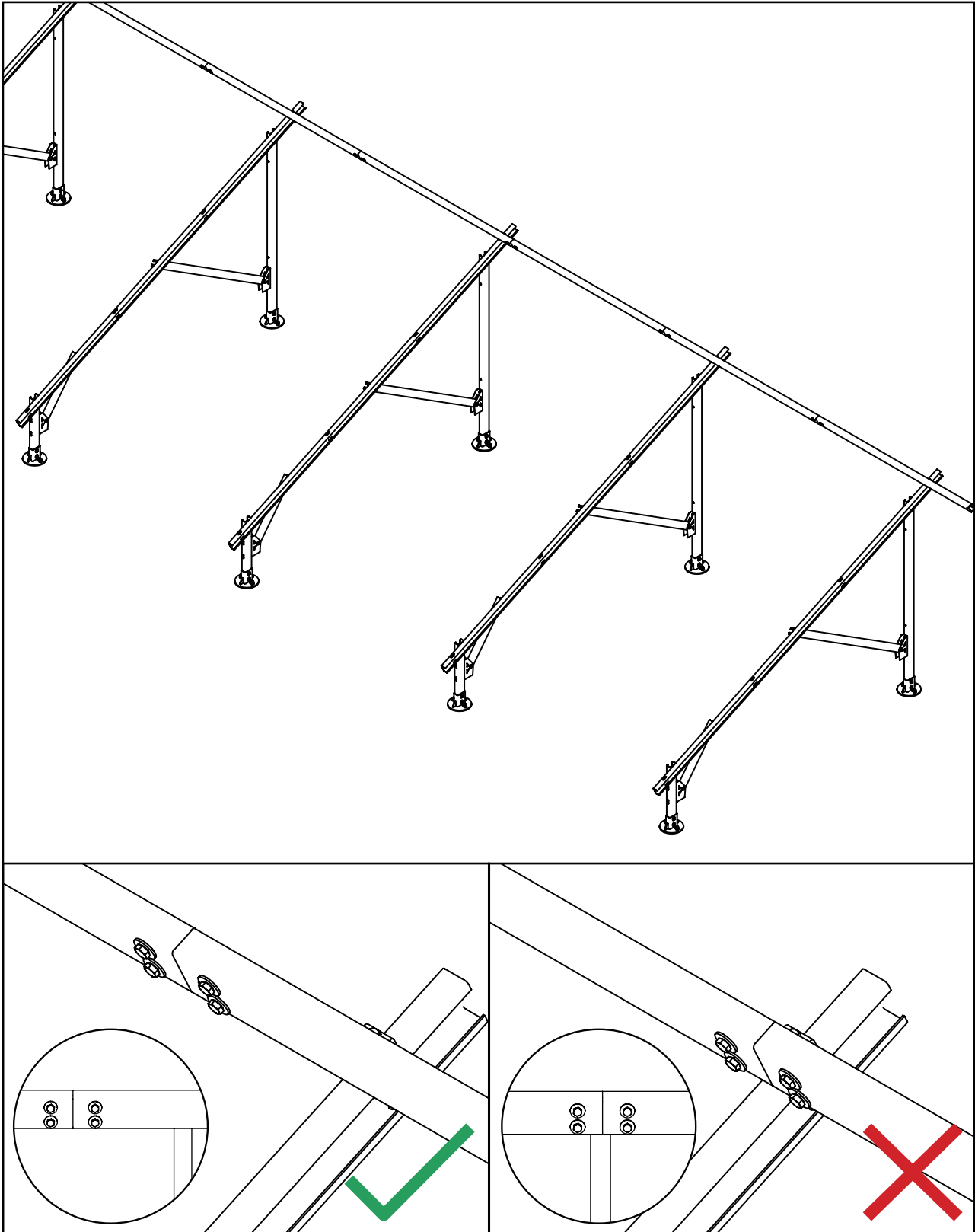

 Keep away panel clamps position from position of rail joiner.

INSTALLING RAIL ONTO THE SUPPORT FRAME

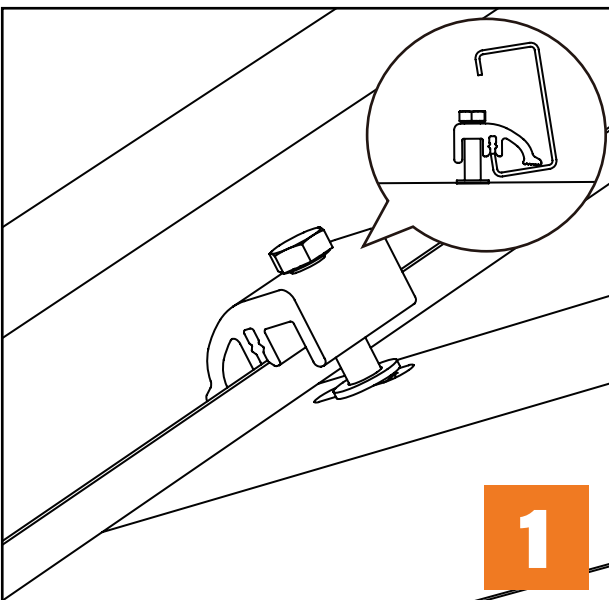
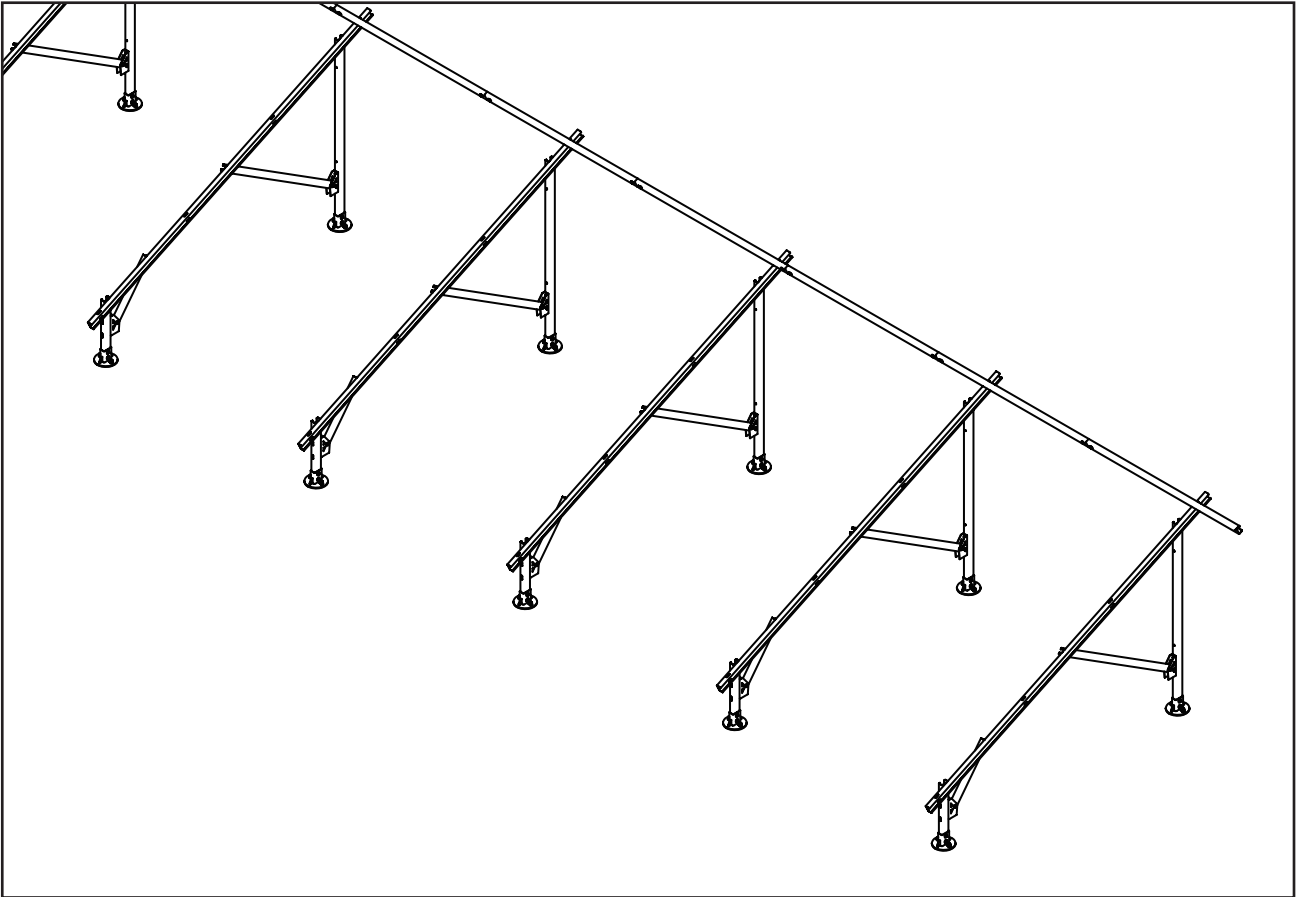

STEP 1
Loosely assemble the rail clamp to allow for positioning and adjustment.

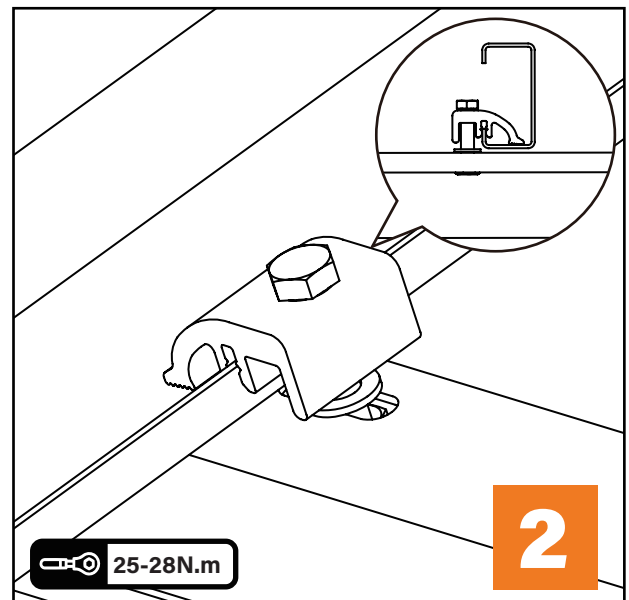

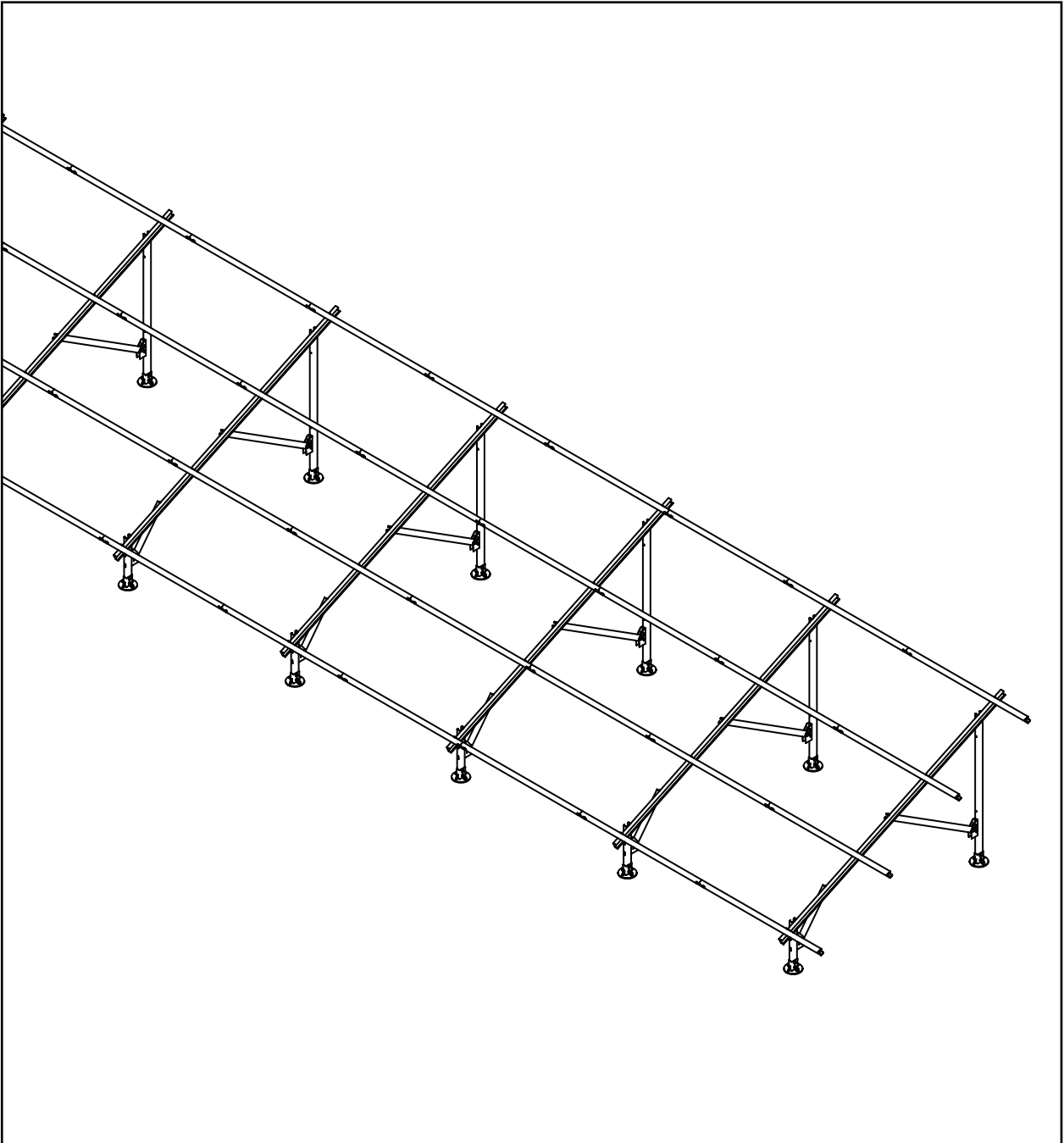

STEP 2
Install the rail, ensuring it is correctly positioned and seated fully within the channel of the rail clamp.
Tighten M10 bolts to the specified torque: 25-28N.m.

RAIL INSTALLATION COMPLETED

Repeat the above steps for each rail until the installation is complete.

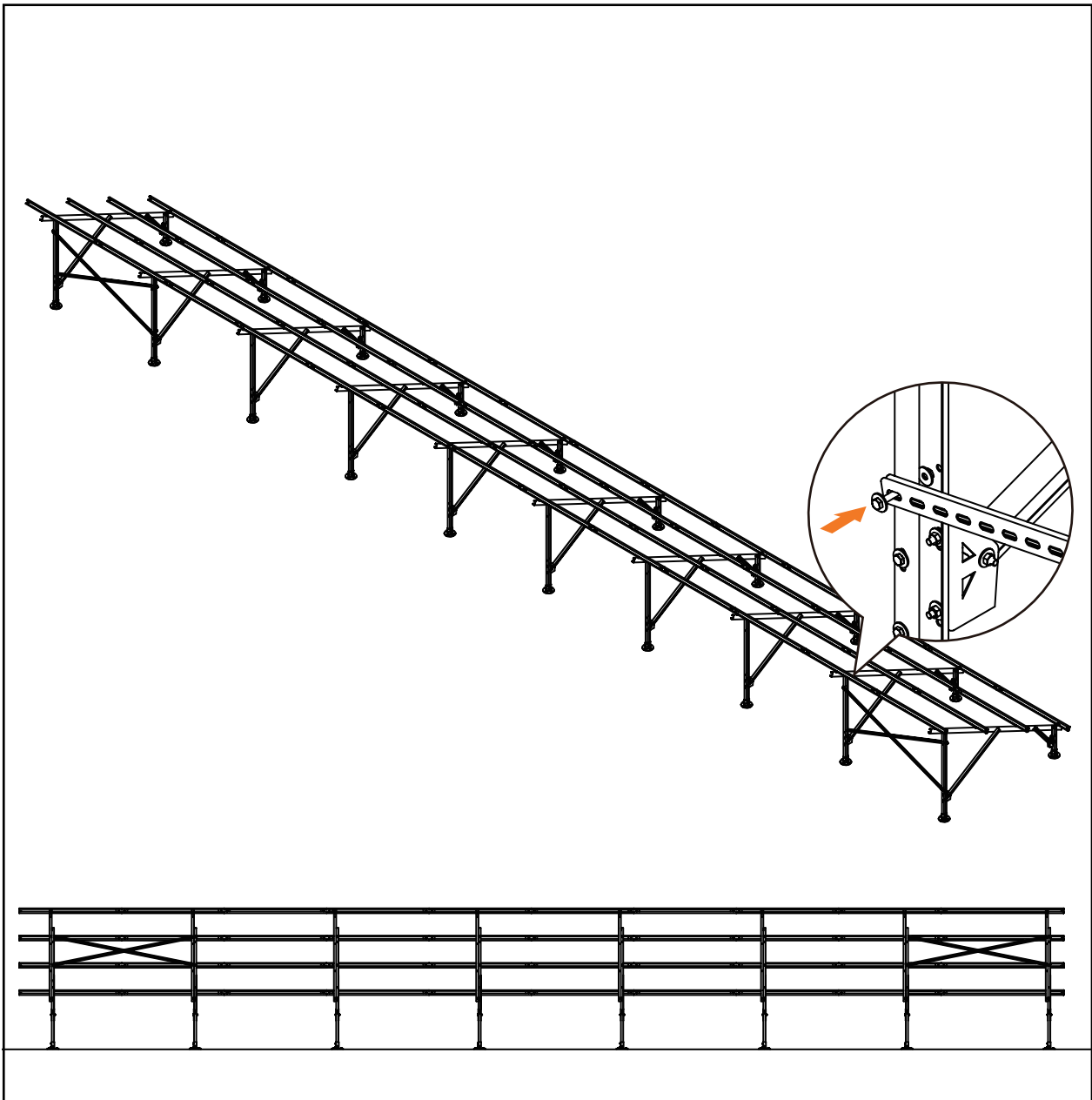
INSTALLING THE REAR SUPPORT BRACE (OPTIONAL)



 This step is optional. Please refer to the technical drawing if required.

NOVA MODULE CLAMPS

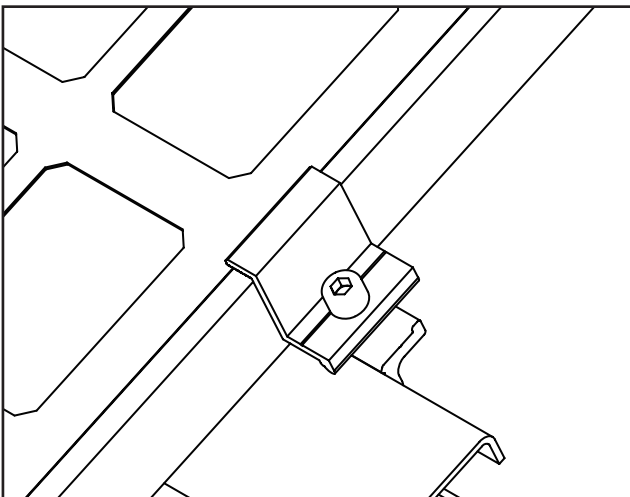
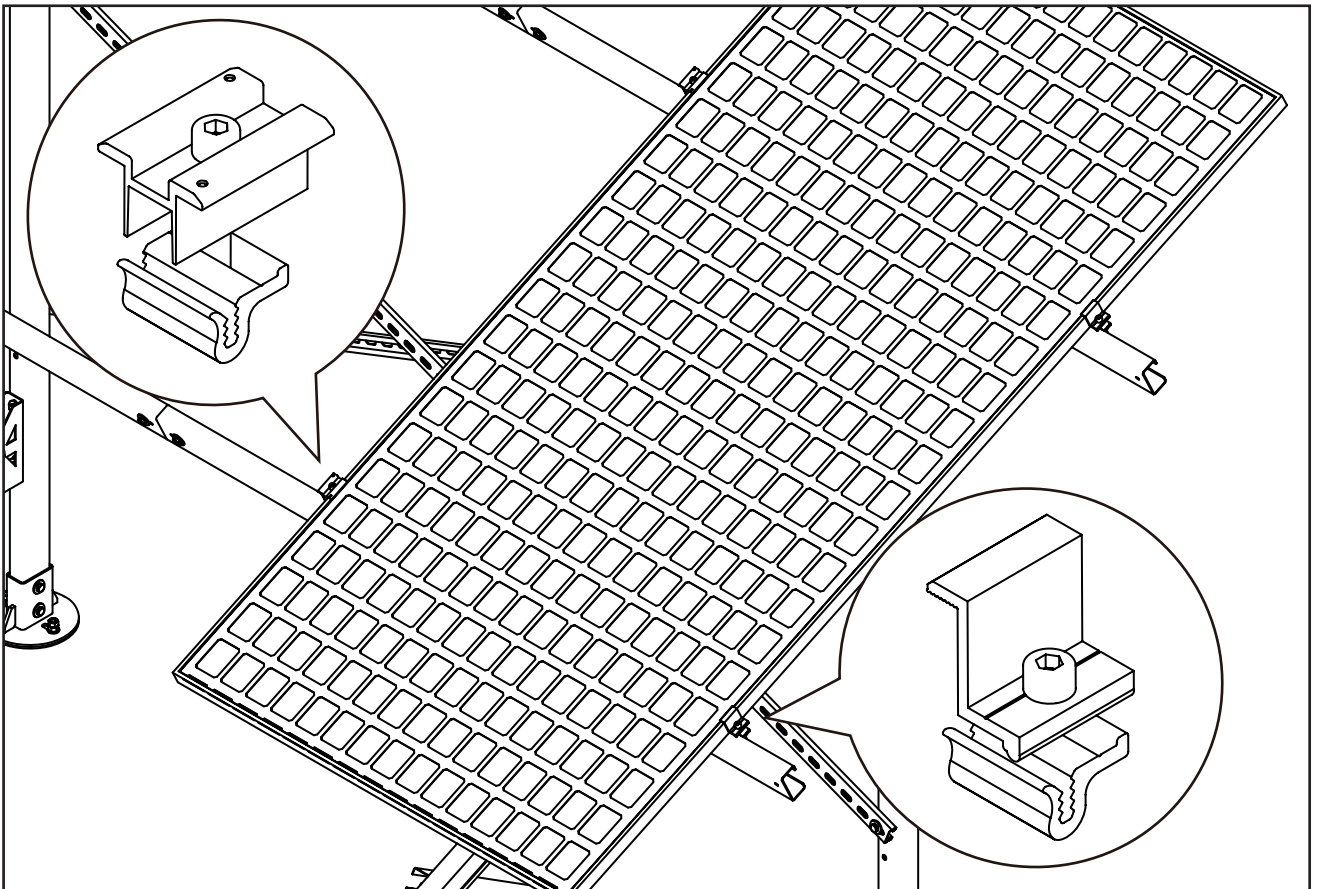

NOVA END CLAMP

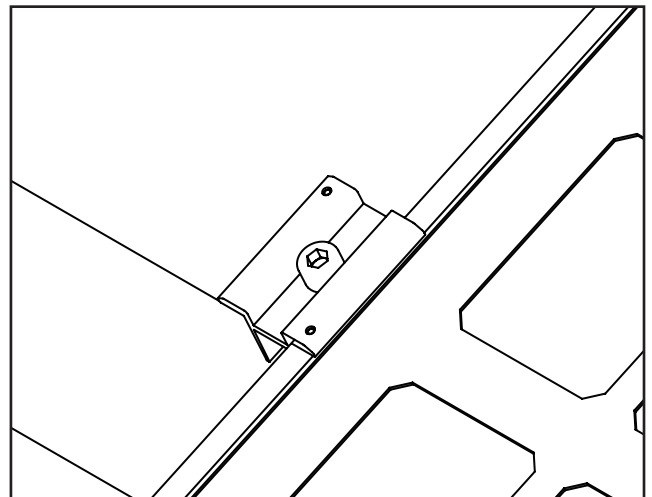

NOVA INNER CLAMP

NOVA provides 2 types of clamps for connecting the modules to the rails. The end clamp is designed to start and finish the row of modules. The inner clamp is designed for the interconnection of modules.

CORRECT POSITIONING OF NOVA MODULE CLAMPS

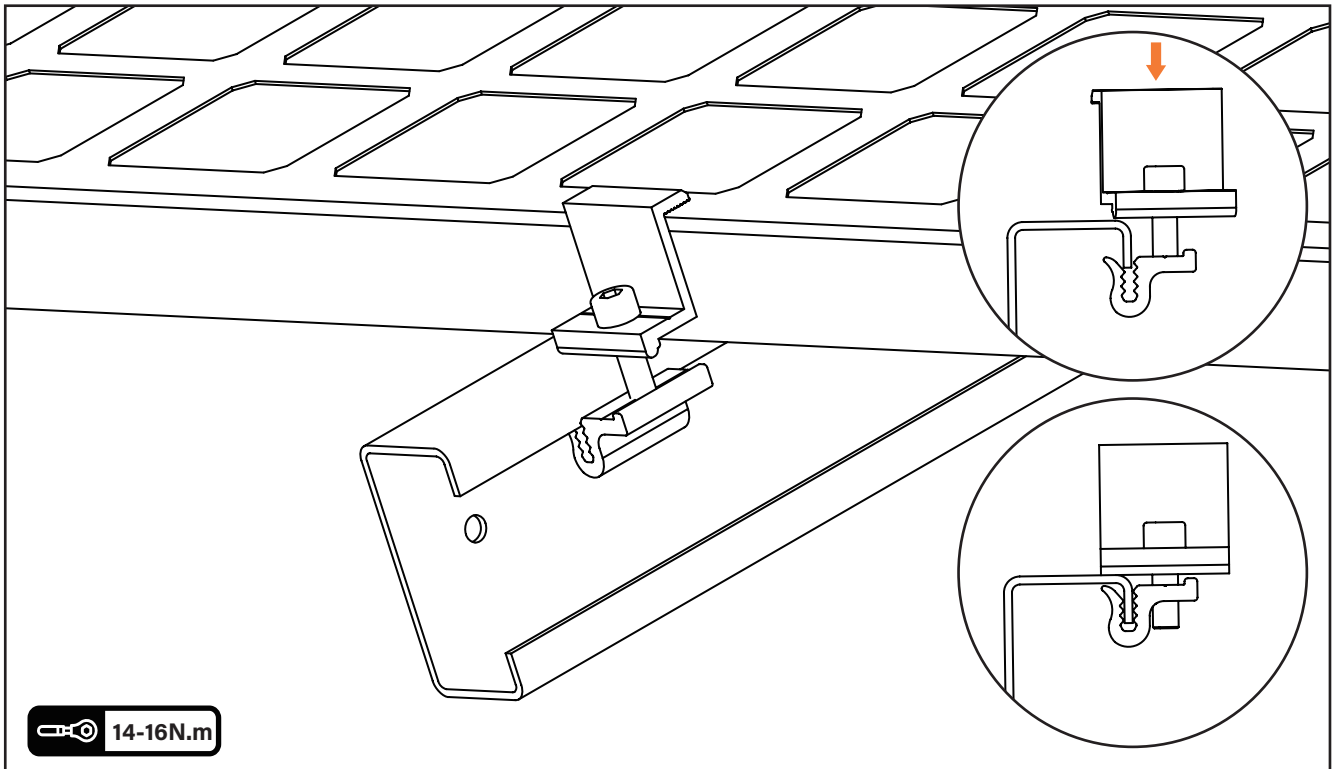

Ensuring it is correctly positioned and seated fully within the rail clamp channel when tightened.

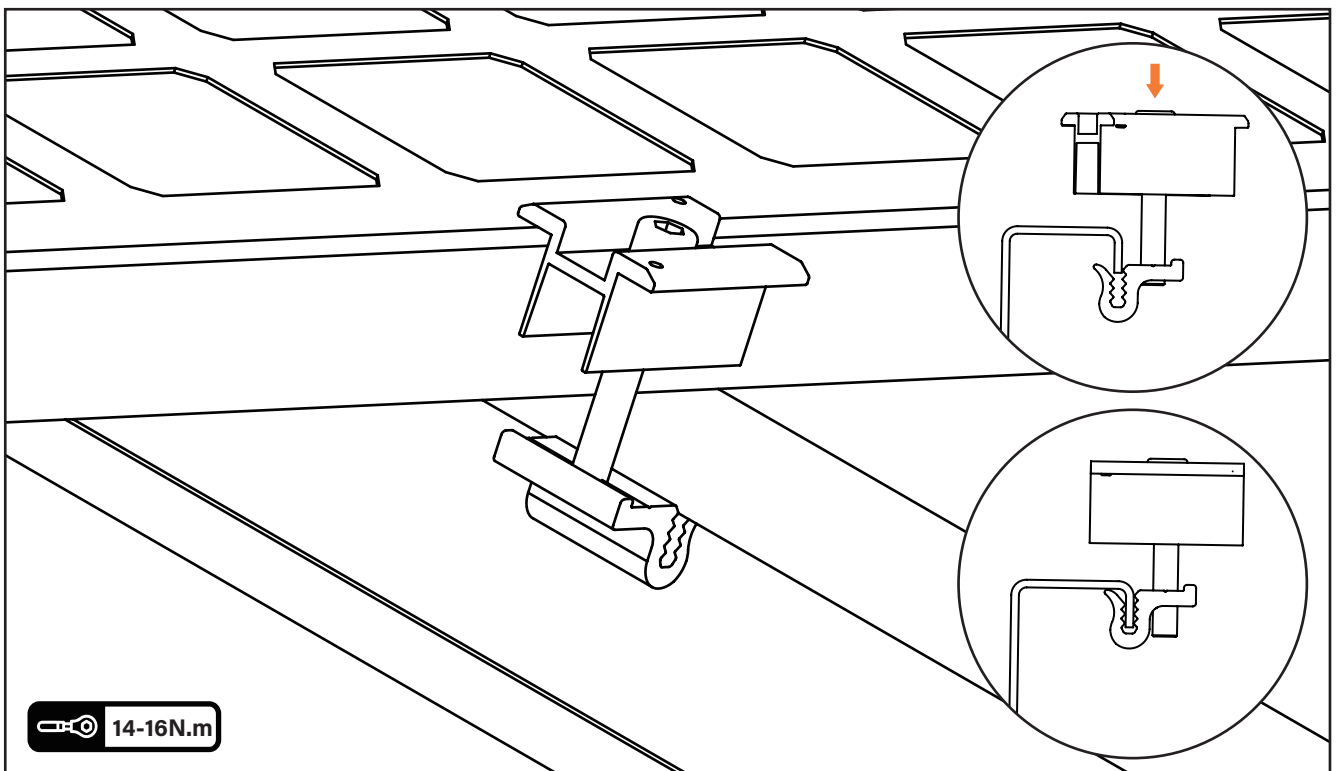

Ensuring it is correctly positioned and seated fully within the rail clamp channel when tightened.

INSTALLING THE FIRST SOLAR MODULE

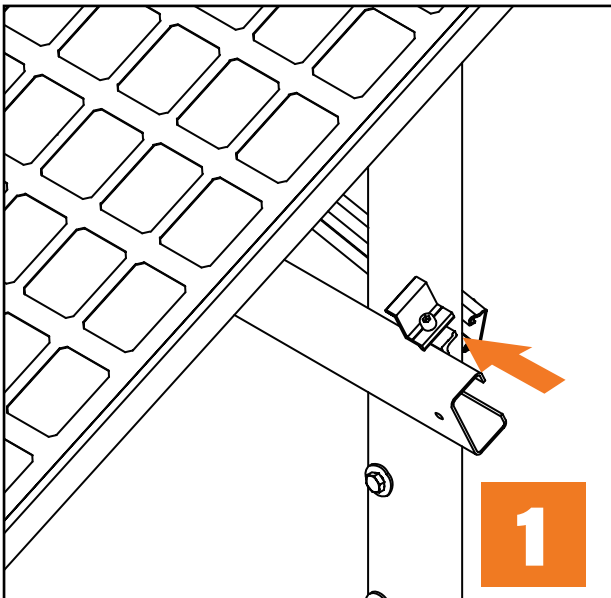
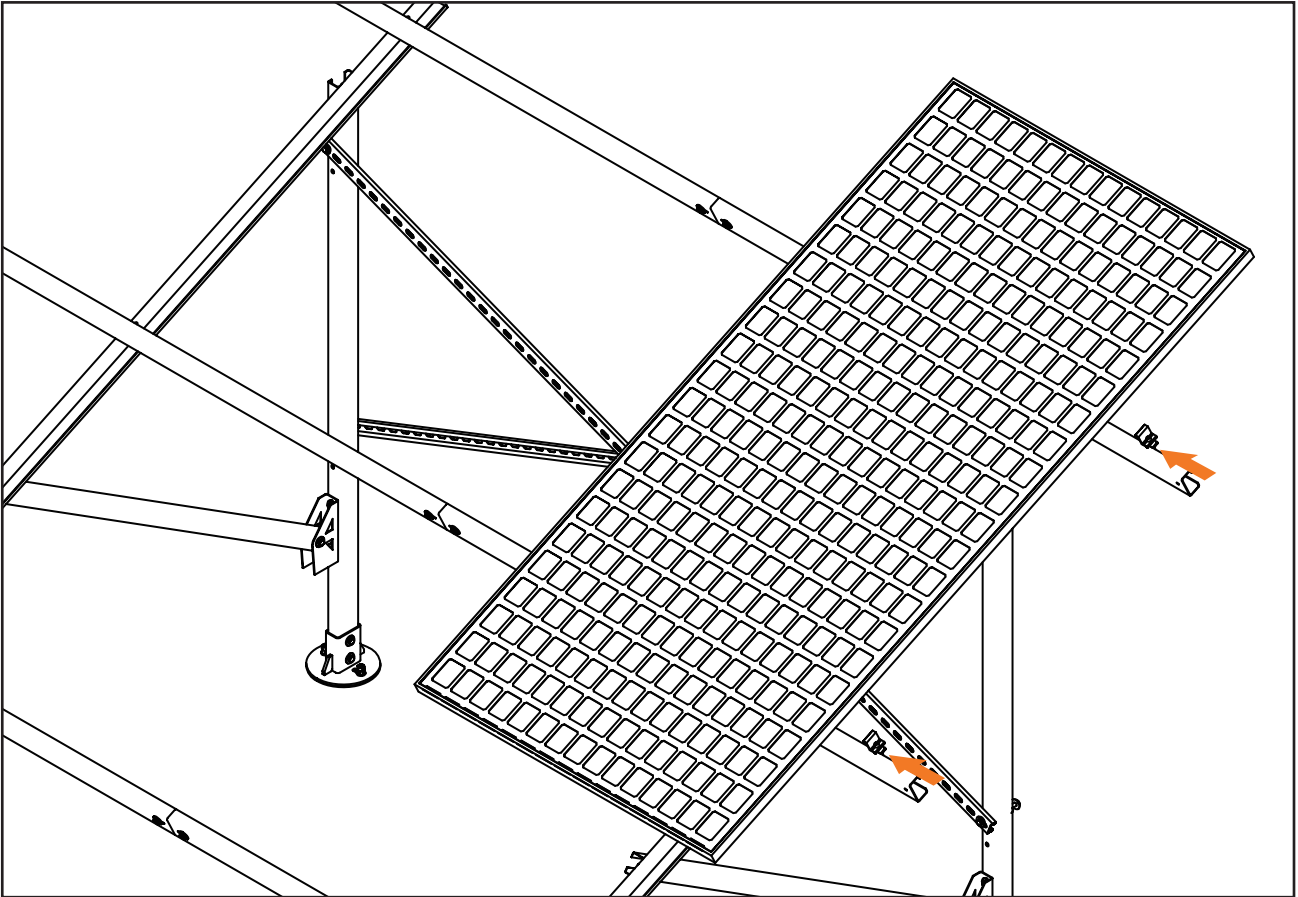

STEP 1
After placing the solar module on top of the rail, ensure it is correctly positioned and aligned. Then hook the end clamp onto the rail.

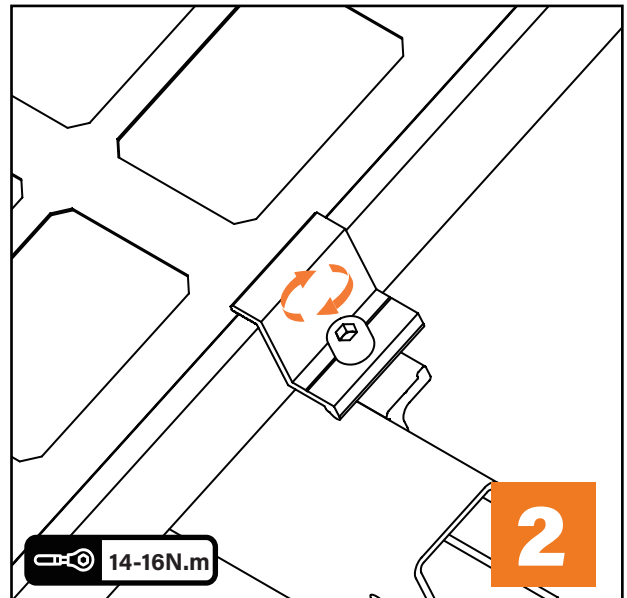

STEP 2
Slide the end clamp until it is flush against the solar module, then tighten the bolt to the specified torque (14-16N.m)

INSTALLING THE SUBSEQUENT SOLAR MODULES

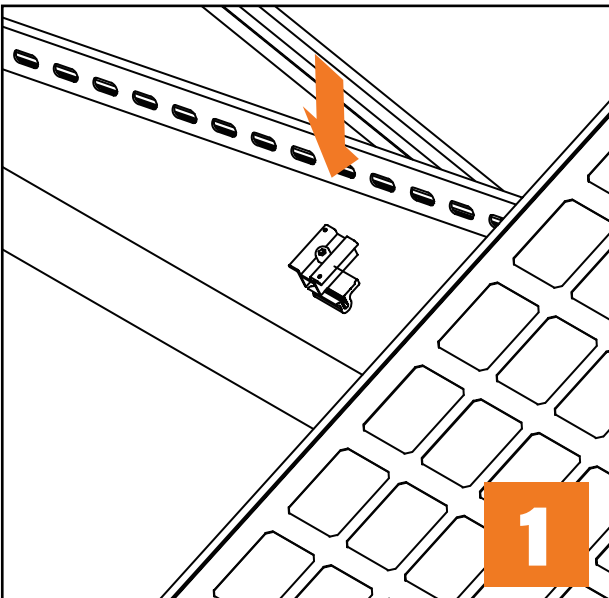
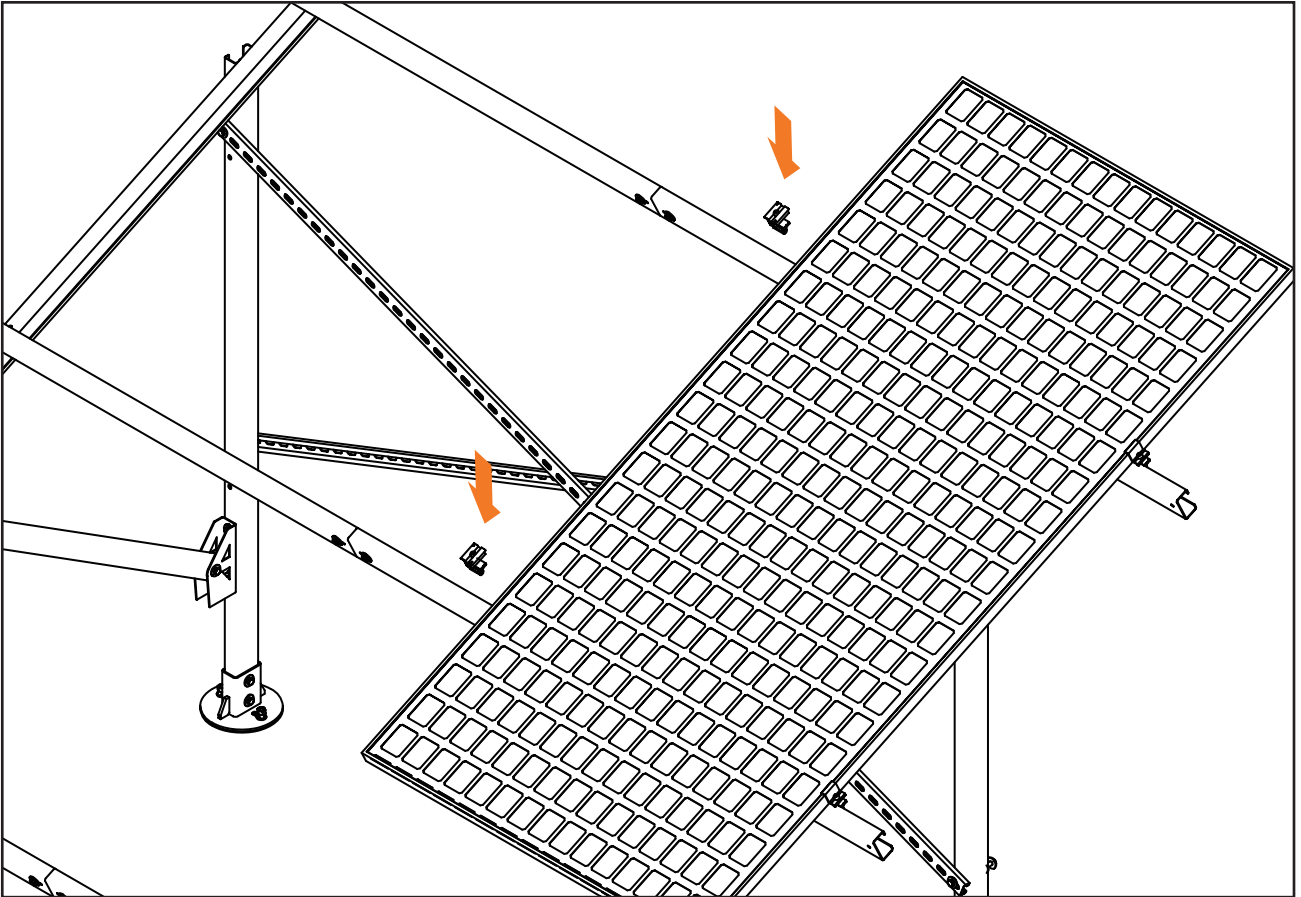

STEP 1
Place the next solar module onto the rail, ensuring it is properly seated and aligned, leaving a small gap to install the inner clamp.

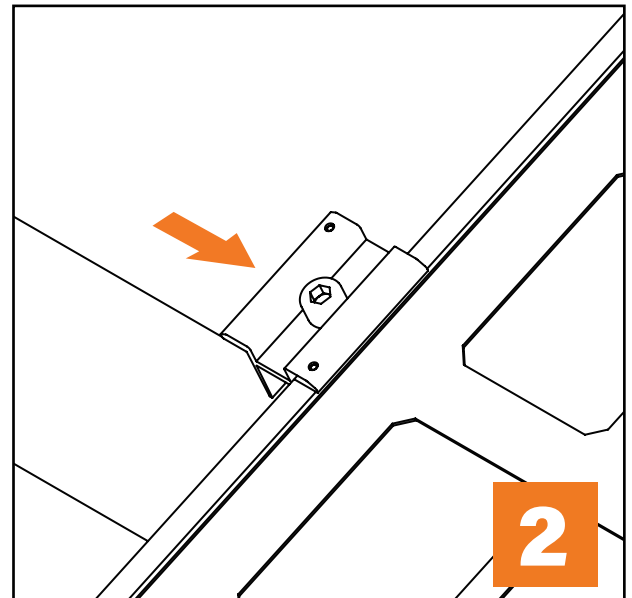

STEP 2
Slide the inner clamps against the edge of the first module. Note: The inner clamps remain free-standing to facilitate positioning of the second module.

INSTALLING THE SUBSEQUENT SOLAR MODULES

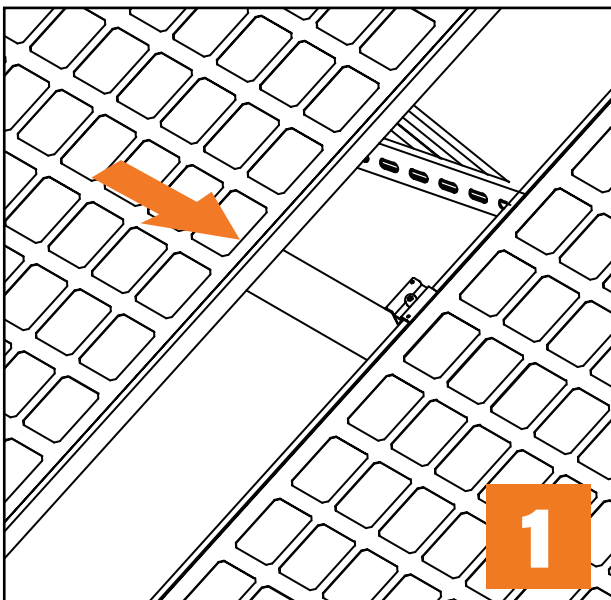
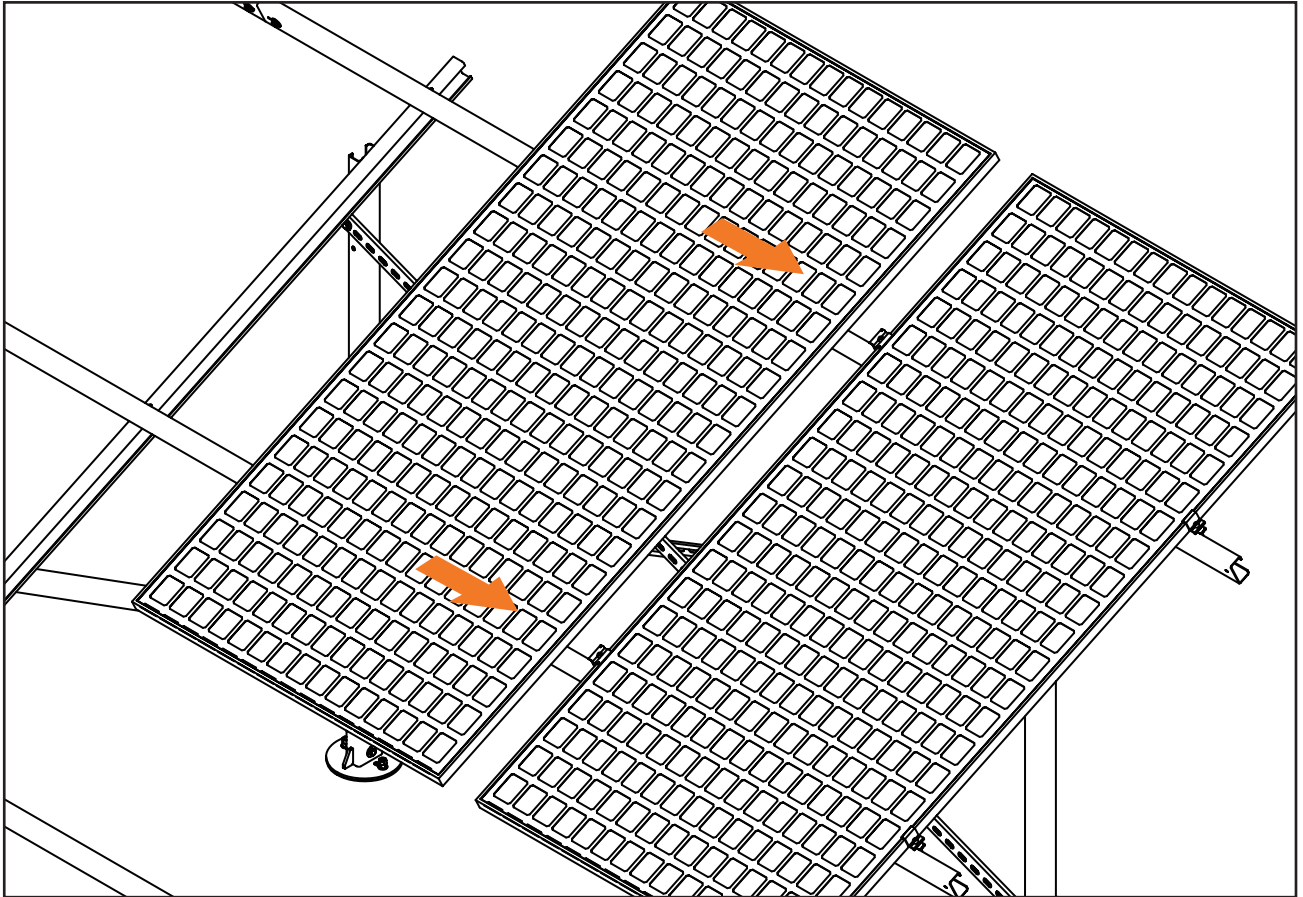

STEP 1
Slide the next module towards the inner clamps and align it using a spirit level, set square, or another straight edge.

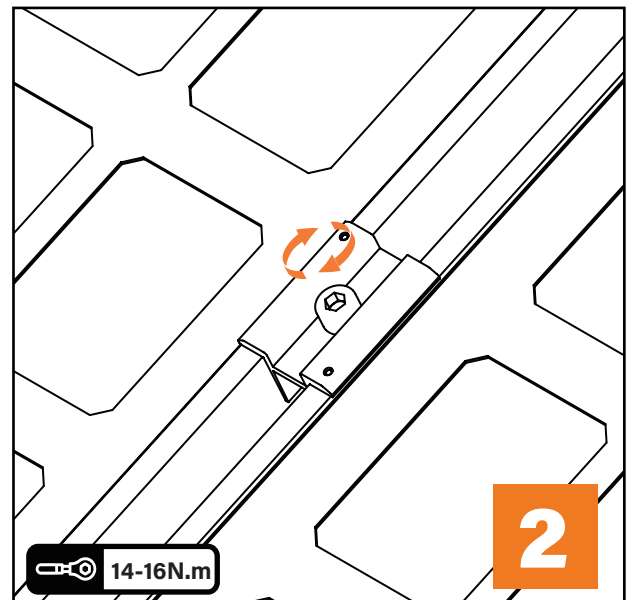

STEP 2
Tighten the inner clamps to the required torque (14-16N.m), ensuring they remain straight and firmly against the module edge.



Continue installing the remaining modules by repeating the same procedure, ensuring alignment throughout.

INSTALLING THE LAST SOLAR MODULE OF THE ROW

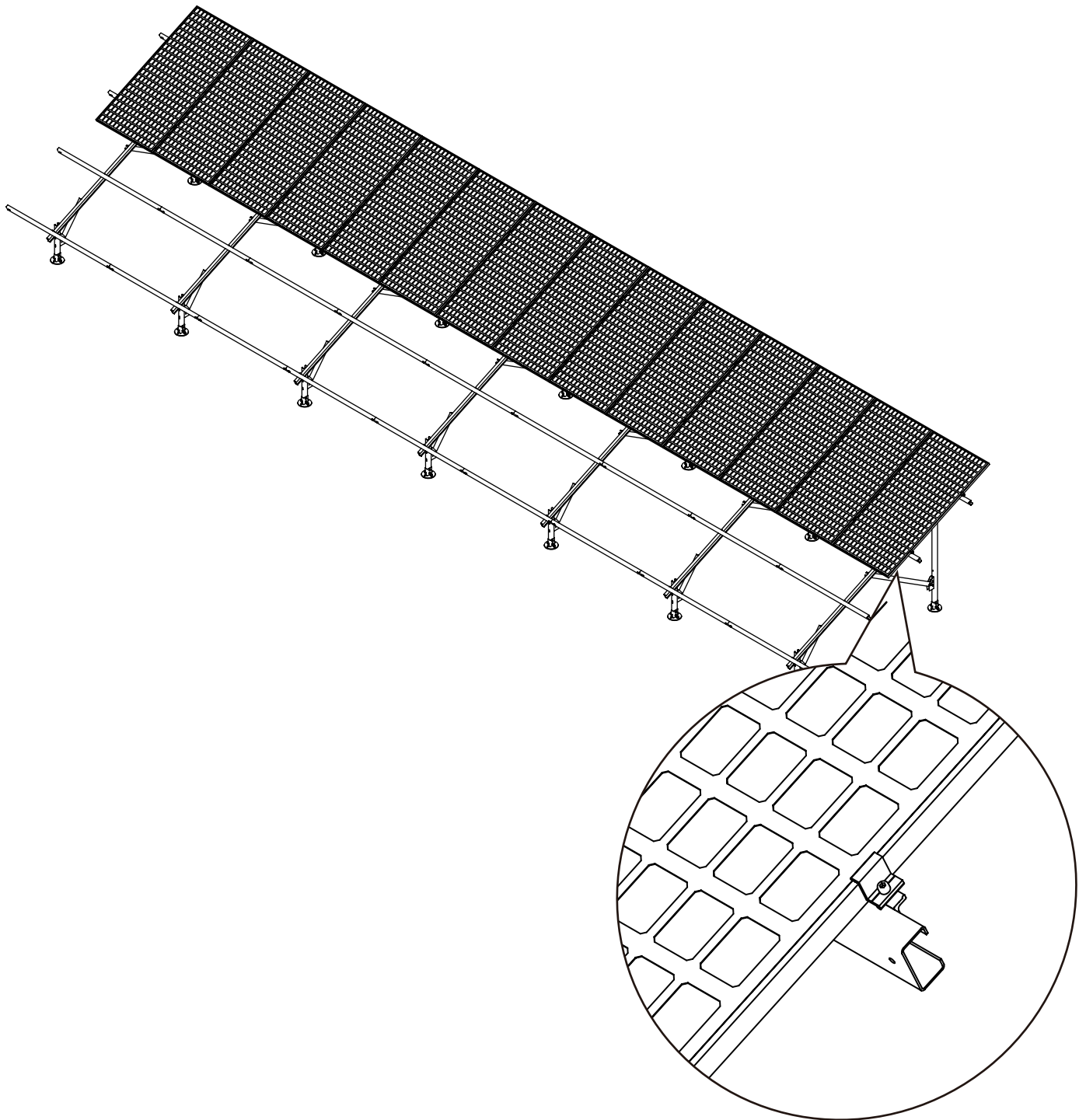

1. Place the last solar module on the mounting rails.
2. Slide the panel tightly against the last inner clamps, ensure the panels are aligned, and tighten to the recommended torque (14–16N.m).
3. Install the final end clamps into position and tighten.



Remember to double-check that all connections have been tightened to the specified torque values.

SOLAR MODULE INSTALLATION COMPLETED

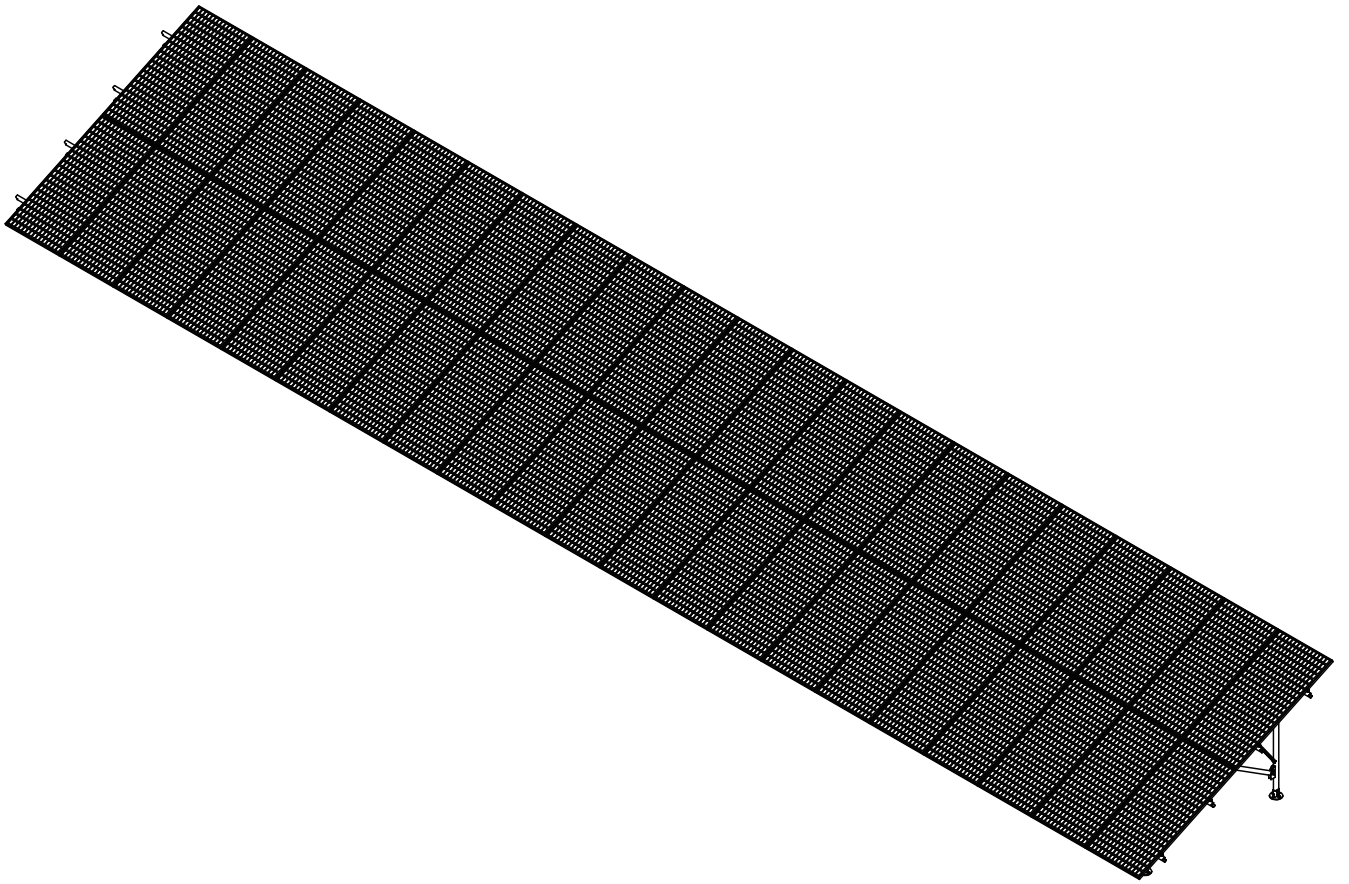

NOVA

